

**Method for Ortho-Phosphate Determination on  
Low-Range Samples**

## 1 PRINCIPLE

This method is designed for the determination of ortho-phosphate in soil, water and other forms of samples. The sample is prepared offline if necessary and then introduced to the FIAlab analyzer. Ortho-phosphates react with molybdate anions to form a yellow colored complex; this complex is reduced to a molybdenum blue species by ascorbic acid.

## 2 SUMMARY

This method is designed for the determination of orthophosphate in high-range samples of various matrices. The method is capable of detecting phosphate in the range of 0.015-3.5mg P / L.

## 3 SAFETY

The toxicity or carcinogenicity of all reagents used in this method must be taken into account and therefore each chemical listed below should be handled accordingly.

Each laboratory is responsible for maintaining compliance with OSHA regulations regarding the safe handling of the chemicals specified in this method. Material Safety Data Sheets (MSDS) should be made available to all personnel using the method.

All waste materials should be disposed of in a responsible manner, in accordance with federal, state and other local regulations.

The following chemicals have the potential to be highly toxic or highly hazardous, for detailed explanations consult the MSDS:

- **Potassium Antimonyl Tartrate Trihydrate**
- **Sulfuric Acid**
- **Sodium Dodecyl Sulfate**

## 4 EQUIPMENT AND SUPPLIES

### Balance:

- Analytical, with a 0.01 g resolution

### Glassware:

- Class A volumetric flasks of at least 50 ml
- Pipettes and appropriate beakers
- Graduated Cylinder
- Plastic Container
- Dark Glass Container

### Flow injection analysis apparatus:

- FIALab-2500 flow injection analyzer
- Tungsten-halogen light source, Ocean Optics HL-2000-LL or corresponding
- FIALab SMA-Z absorbance flow cell with 10 mm light path
- Spectrophotometer, Ocean Optics USB4000-VIS/NIR or corresponding
- FIALab Fiber optic cables (2)
- FIALab flow through (FT) heater

### Autosampler (for high sample loads):

- Cetac ASX-260/520 or AIM-3200/3300

## 5 REAGENTS AND STANDARDS

### 5.1 List of chemicals

- Deionized water, (H<sub>2</sub>O) [CAS - 7732-18-5].
- Ammonium molybdate tetrahydrate, ((NH<sub>4</sub>)<sub>6</sub>Mo<sub>7</sub>O<sub>24</sub>\*4H<sub>2</sub>O) [CAS - 12054-85-2]. Sigma-Aldrich P/N 09880 or corresponding.
- Potassium antimonyl tartrate trihydrate (C<sub>8</sub>H<sub>4</sub>K<sub>2</sub>O<sub>12</sub>Sb<sub>2</sub>\*3H<sub>2</sub>O) [CAS - 28300-74-5]. Sigma-Aldrich P/N 383376 or corresponding.
- Sulfuric acid (36N), (H<sub>2</sub>SO<sub>4</sub>) [CAS - 7664-93-9]. Sigma-Aldrich P/N 258105 or corresponding.
- L-Ascorbic acid, (C<sub>6</sub>H<sub>8</sub>O<sub>6</sub>) [CAS - 50-81-7]. Sigma-Aldrich P/N 255564 or corresponding.
- Sodium dodecyl sulfate, (CH<sub>3</sub>(CH<sub>2</sub>)<sub>11</sub>OSO<sub>3</sub>Na) [CAS - 151-21-3]. Sigma-Aldrich P/N 436143 or corresponding.

## 5.2 Preparation of reagents

**Carrier:** Matrix match carrier to samples. Salt solution to seawater samples, extraction solution for soil samples, etc.

### Reagent 1: 6mM Ammonium Molybdate (1L)

- Mix 40ml of sulfuric acid into 800ml of DI water. Let cool to room temperature.
- Add 10.0g of ammonium molybdate tetrahydrate and 0.2g potassium antimonyl tartrate trihydrate and mix until completely dissolved.
- Add deionized water to a total volume of 1L.
- Transfer solution to a tightly capped plastic bottle.

### Reagent 2: 300mM Ascorbic Acid (1L)

- Dissolve 30.0g ascorbic acid in 600ml of DI water.
- Add 1.0g sodium dodecyl sulfate and mix until dissolved. Mix slowly to prevent foaming.
- Add deionized water to a total volume of 1L.
- Transfer solution to a dark glass bottle.

**Note:** Use of high quality laboratory glass bottles is important.  
 Reagent 1 should be prepared every four weeks.  
 Reagent 2 degrades quickly and should be prepared fresh daily.

## 5.3 Preparation of standards

- Dilute 1000 mg/L P-(PO<sub>4</sub>) stock solution with deionized water to the desired range of phosphate standards. Prepare fresh daily.

## 6 SAMPLE COLLECTION AND PRETREATMENT

This protocol only covers the analysis process. Sample collection and pretreatment depends on the type of sample and will have to be determined separately.

## 7 INSTRUMENT SETUP – LOW-RANGE

### Flow injection analysis apparatus parameters:

- Peristaltic pump tubing: Tygon, 1.02mm/0.04in ID (white/black), FIAlab P/N 270300
- Sample injection loop: 140 $\mu$ L - 12.0in/30cm of Teflon capillary tubing with 0.03in/0.75mm ID, FIAlab P/N 270040
- Reaction coil 1: 750 $\mu$ L - 65.0in/165cm of Teflon capillary tubing with 0.03in/0.75mm ID, FIAlab P/N 270040
- Reaction coil 2 (Heated Reaction Coil): 750 $\mu$ L - 65.0in/165cm of Teflon capillary tubing with 0.03in/0.75mm ID, FIAlab P/N 270040
- SMA-Z flow cell: light path -100mm
- Flow rate: 50% pump speed (approx. 2.0 mL/min flow rate per pump channel)
- Heater temperature: 45C

### Recommended spectrometer parameters:

Primary wavelength: 870nm

Second wavelength: 655nm

Third wavelength: 545nm

Fourth wavelength: 520nm

Reference wavelength: 490nm

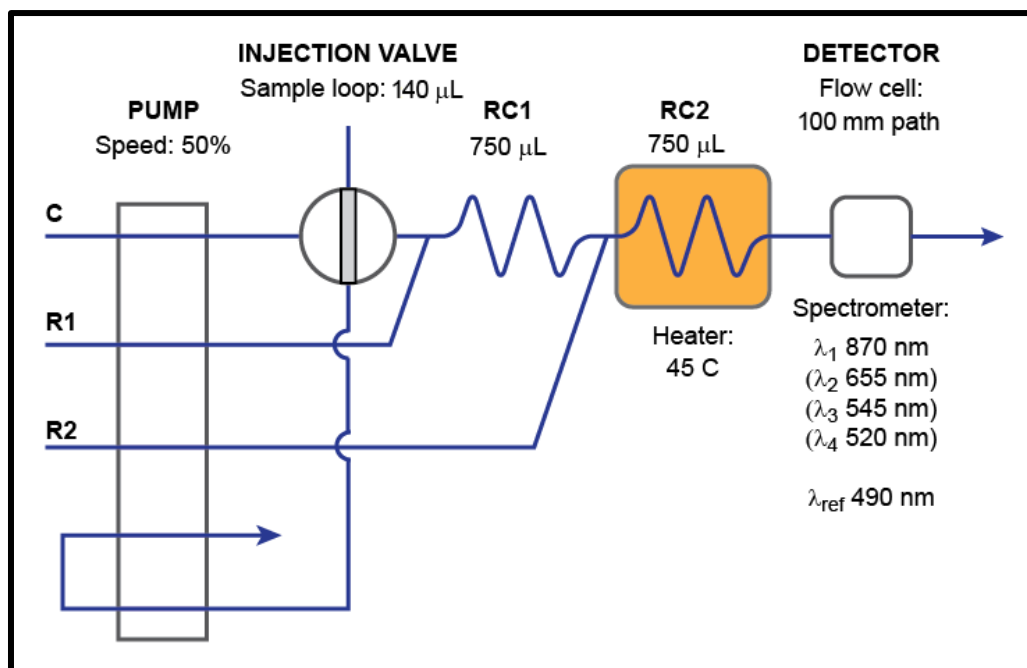

Fig. 1- Flow schematic for low-range phosphate determination on a FIAlab-2500

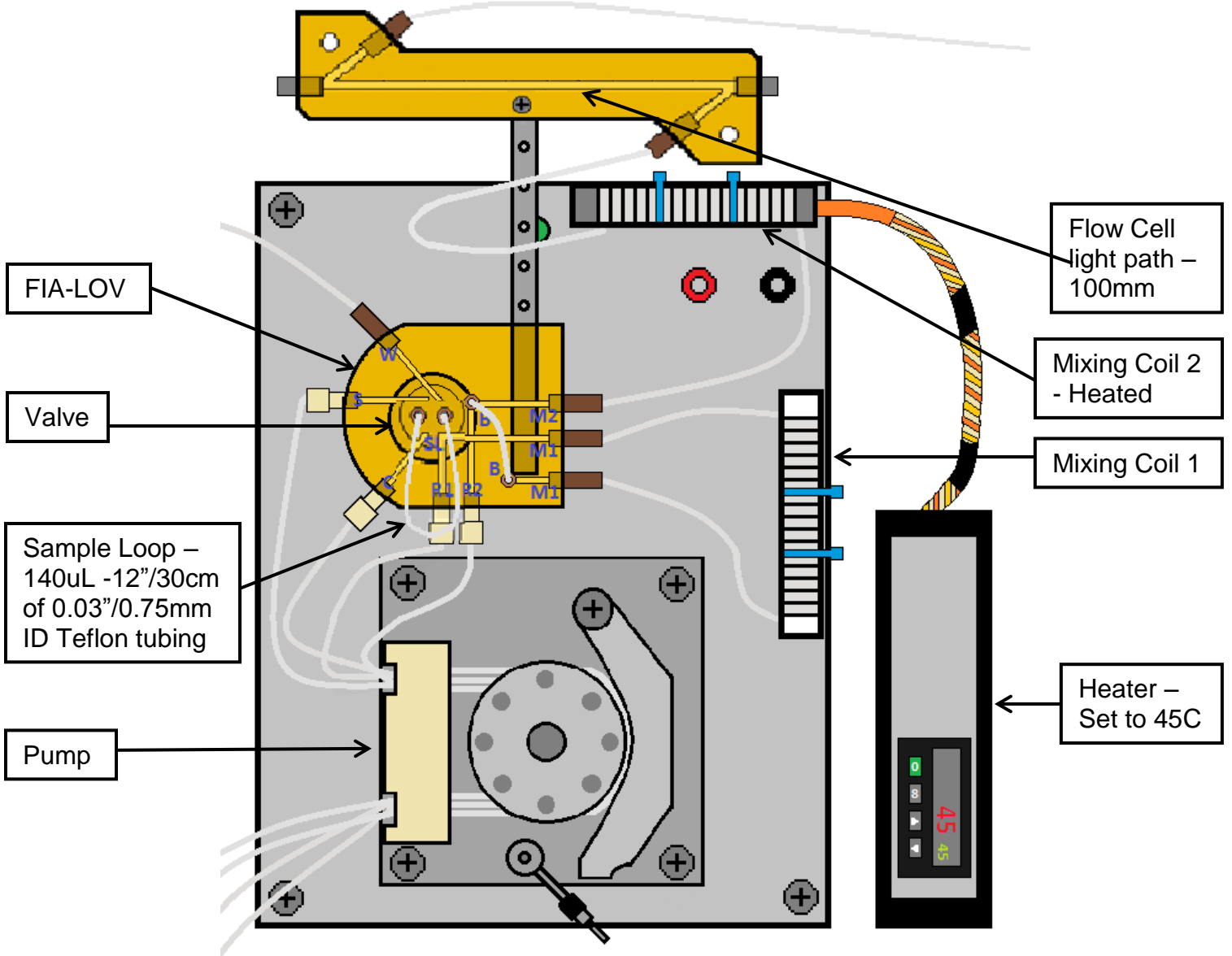

Fig. 2- Pictorial representation of low-range phosphate setup on a FIAlab-2500

The program script using an autosampler is shown below. For manual sample introduction see the FIAlab for Windows software manual.

```
'Phosphate Assay

'FIA Template for FIAlab-2500 System
Global Logon 'logon to all components
Sample Description 'load sample description file
Injection Valve Sample Load
Optimize_FIAlab2500

'Set Wavelengths (for Ortho)
'Note: for Olsen or Bray set wavelengths to
'880, 890, 900, 925 nm
Hardware Settings Wavelength 1 (nm) 870
Hardware Settings Wavelength 2 (nm) 655
Hardware Settings Wavelength 3 (nm) 545
Hardware Settings Wavelength 4 (nm) 520
Reference Wavelength1 490

'Set delay time, start pump to prime lines
Valve Delay 8000 'sample inject (msec)
Peristaltic Pump Clockwise(%) 50
Injection Valve Sample Load
Delay (sec) 40
Hardware Settings Optimize Integration

'Put autosampler in first sample (usually a blank)
Next Sample
Delay (sec) 25

LoopStart (#) 5000

'Inject sample, load next sample
'Autosampler wash
Analyte New Sample
Next Sample
Injection Valve Sample Inject
Delay (sec) 3

'Perform reference scan and start absorbance scans
Spectrometer Reference Scan
Spectrometer Absorbance Scanning
Delay (sec) 35
Spectrometer Stop Scanning

'Refresh plots and update concentrations
Refresh Plot

'Method clean up (at end of run)
If sampleid < 0 Then
  autosampler Wash
  'Save Data Date-Time .dat
End If

Loop End
```

## 8 PERFORMANCE METRICS

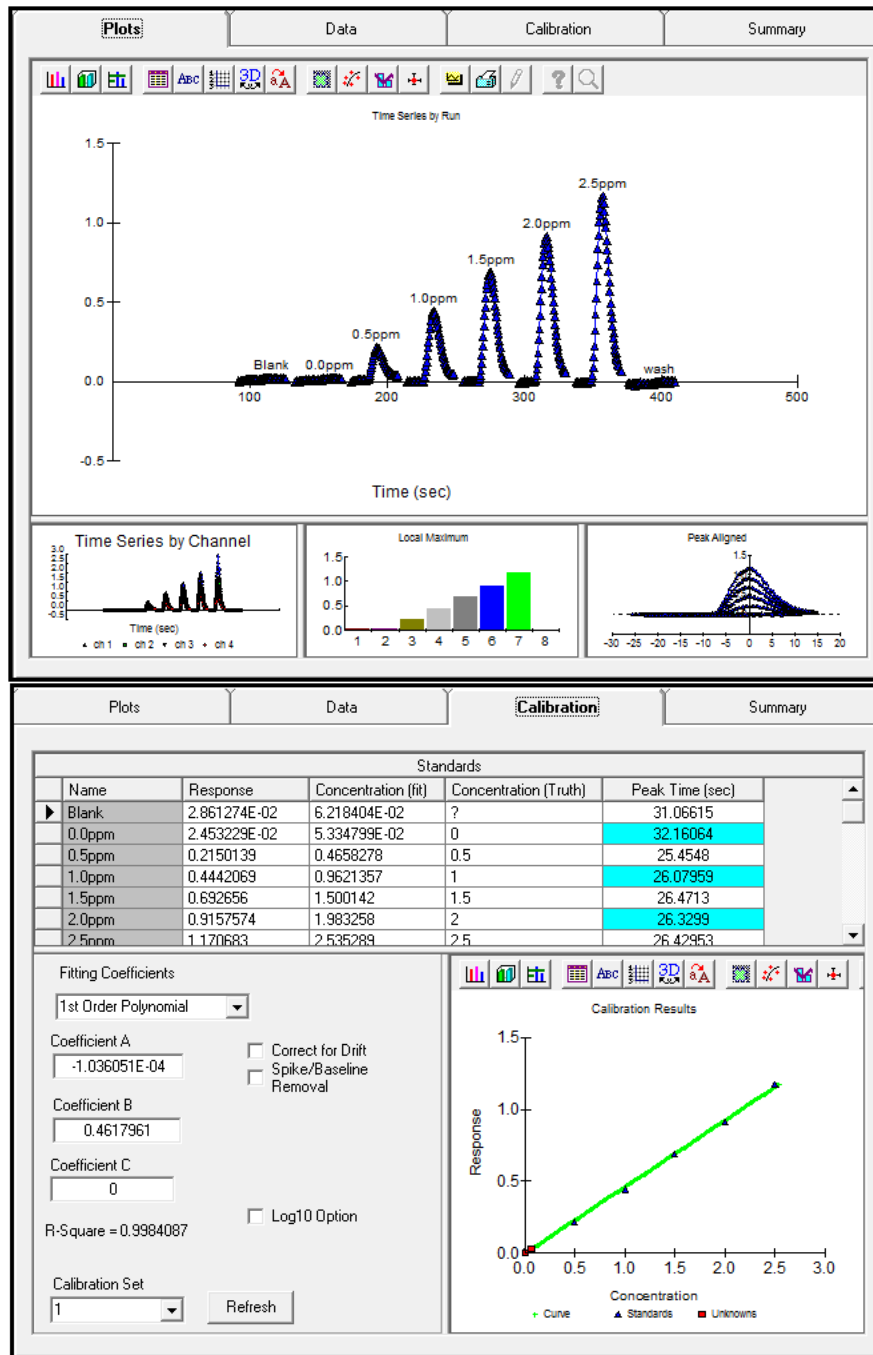

Fig. 3 – Example plot and calibration data for low-range phosphate at 545nm

Lower limit of detection: 0.015mg/L –  $4.8 \times 10^{-7}$  mol/L  
 Upper limit of detection: 3.5mg/L –  $1.1 \times 10^{-4}$  mol/L  
 Sample throughput: 85 samples/hr  
 Startup: 5 minutes  
 Shutdown: 5 minutes



*FIAlab*<sup>®</sup>



[www.flowinjection.com](http://www.flowinjection.com)